

NB: TOWN PARK INFORMATION SIGN SIMILAR CONSTRUCTION, EXCEPT:
 1. DELETE FIN;
 2. ALLOW 40mm FRAME REVEAL AS SHOWN; AND
 3. 900 UPPER PANEL SIZE.

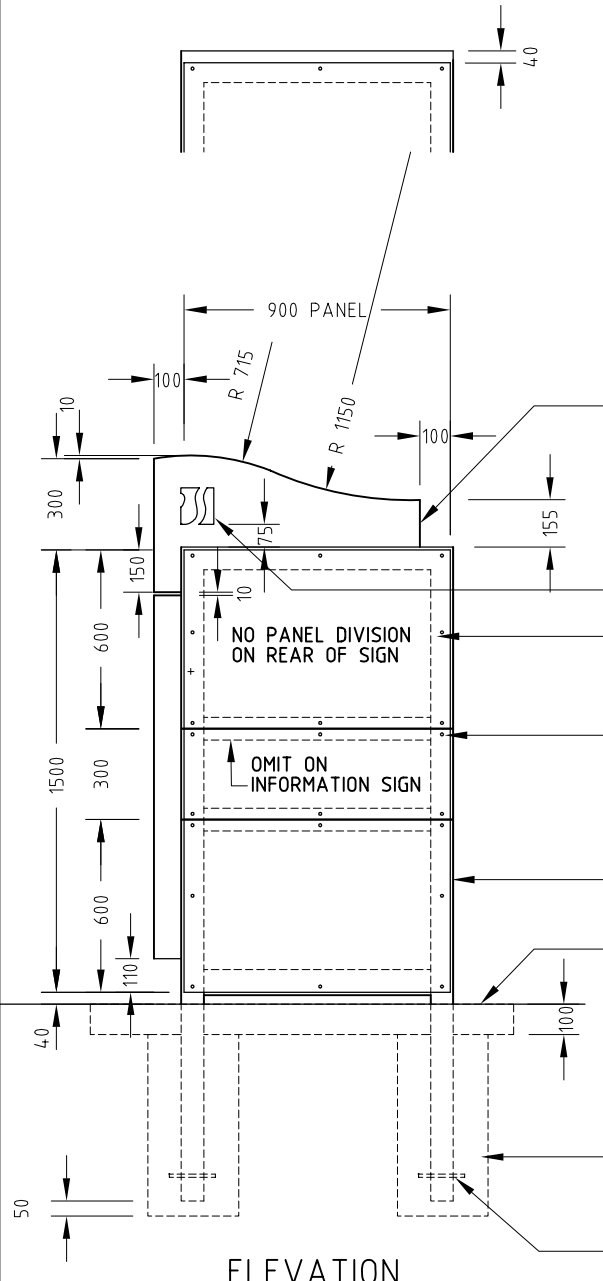

ATTACH FIN PLATE TO FRAME BY 100 ON 100 OFF STITCH WELD CONTINUOUS BODY FILL BEFORE PAINTING TO HIDE WELDS

120 x 110 RELIEF LOGO FROM NOM 1.6mm GALV M.S. SHAPE LASER CUT FROM DIGITAL FILE, EPOXY TO STEEL FIN PRIOR TO PRIMING AND PAINTING

FABRICATE FRAME FROM 75 SHS 3.0 DURAGAL VANDAL PROOF 'SNAKE EYES' STAINLESS 10x16x30MM (#10, 1-1/4") SCREWS AT 300 C/C. PAINT HEADS TO MATCH PANEL COLOUR. SCREWS RECESSED INTO PANEL SO HEAD IS FLUSH WITH SURFACE. ALL HOLES AND RECESSES TO BE MADE PRIOR TO PAINTING.

FRAME TO EXCEED SIGN FACE DIMENSIONS BY 10mm ON ALL SIDES

FINISH FOOTINGS 100 BELOW GROUND LEVEL IN ALL LOCATIONS

GRASSED AREAS ONLY - CONSTRUCT 100mm THICK 20MPa CONCRETE MOWING STRIP

FOOTING 300 DIA x 600 DEEP (MIN) 20 MPa CONCRETE INTO UNDISTURBED NATURAL GROUND

10mm DIA GALV LOCKING PIN

SIGNS ARE TO BE INSTALLED TRUE AND PLUMB WITH POSTS VERTICAL AND SIGN FACES HORIZONTAL AND SQUARE.

FOOTINGS SHOWN DASHED

GRASSED AREAS ONLY - 1400 X 500 X 100mm THICK MOWING STRIP

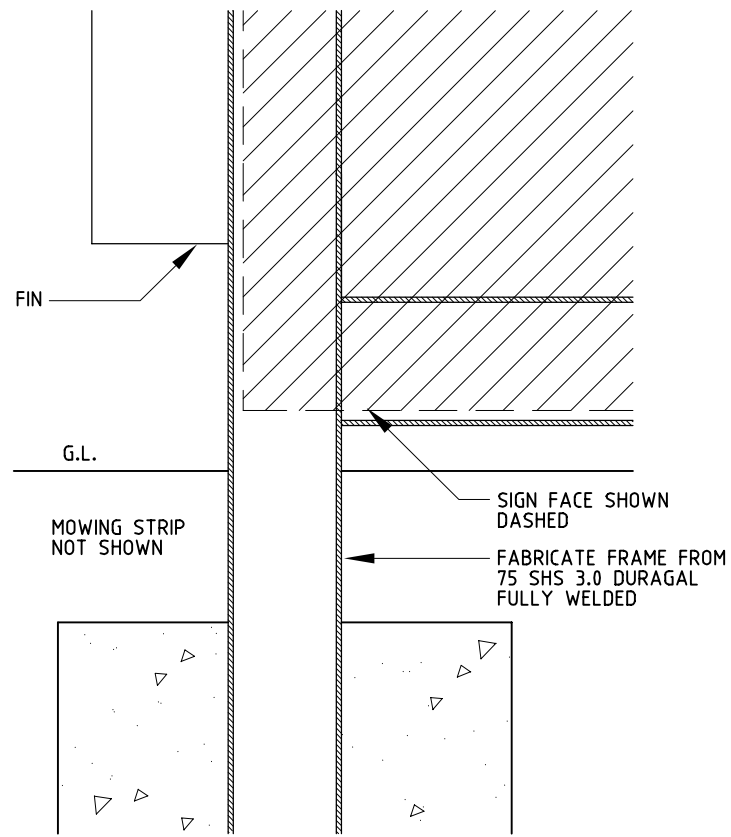

DETAIL SECTION 1:5

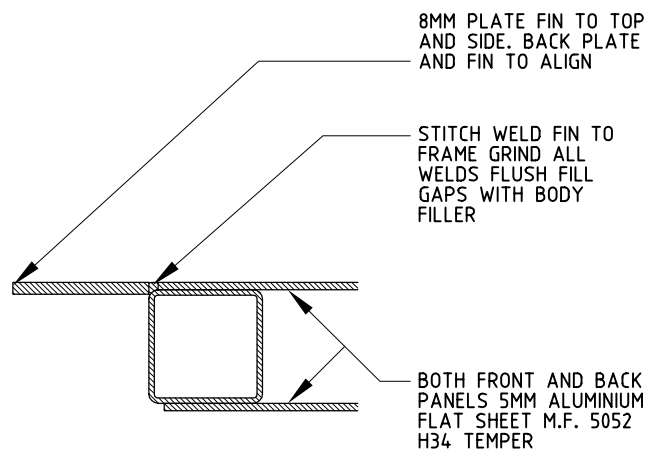

DETAIL PLAN 1:5

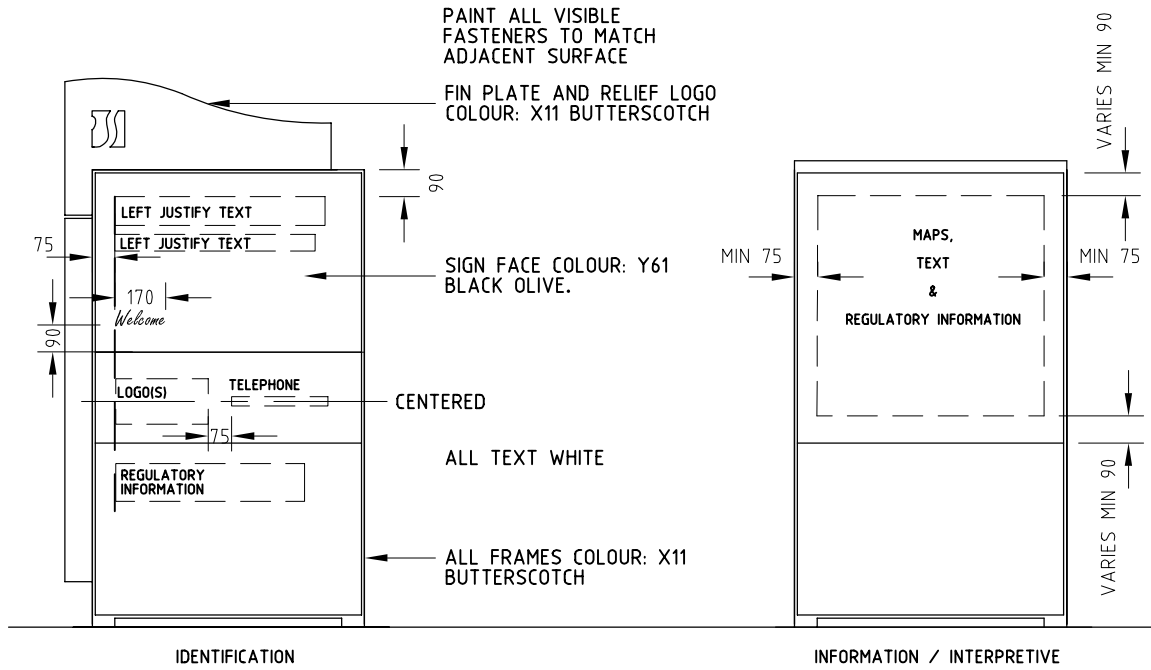

FINISHES & TYPICAL GRAPHIC LAYOUT 1:25

NOTES

1. ALL WORK AND MATERIALS ARE TO COMPLY WITH THE LATEST RELEVANT AUSTRALIAN STANDARDS AND CODES.
2. GRAPHICS, TEXT & LOGOS TO PROJECT REQUIREMENTS AND ACT GOVERNMENT BRANDING POLICY AT TIME OF INSTALLATION. REFER DESIGN STANDARD 25 FOR GRAPHIC GUIDELINES.
3. GRIND WELDS SMOOTH AND REMOVE WELD SPATTER. MAKE SMOOTH ALL SHARP OR HAZARDOUS EDGES. COLD GALVANISE PAINT ALL AREAS DISTURBED PRIOR TO PAINT FINISH APPLICATION.
4. FOR GALVANISED SURFACES SURFACE PREPARATION MAY INVOLVE DEGREASING, SOLVENT CLEANING AND ETCHING OR LIGHT BRUSH BLASTING. FINISHED SURFACES ARE TO BE SMOOTH AND FLAT WITH PAINT EVENLY APPLIED.
5. PAINT FINISH SHALL BE EQUAL TO DE BEER COLOUR SYSTEMS BERTHANE FLEET SERIES 700 - HIGH GLOSS, NON-YELLOWING, 2-PACK POLYURETHANE FINISH (AIR-DRYING OR FORCE-DRYING). INCLUDE SURFACE PREPARATION, EDGE PRIMER, UNDERCOAT PRIMER, 2 SATIN FINISH FINISHING COATS OF PAINT AND 2 HEAVY FINISHING COATS OF CLEAR TWO PACK POLYURETHANE.
6. SIGN MESSAGES, GRAPHICS AND PICTOGRAMS MASKED AND SPRAYED ON PAINTED SIGN FACES. ALL GRAPHICS TO BE PERMANENTLY APPLIED AND ACCURATELY REPRODUCED FROM ELECTRONIC FILES.
7. TREAT ALL EXPOSED SURFACES WITH APPROVED SACRIFICIAL, INVISIBLE ANTI GRAFFITI TREATMENT SUCH AS PSS 20 OR EQUAL.

ACT GOVERNMENT

DESIGN STANDARD
URBAN INFRASTRUCTURE

Authorised Signature

Drawn JP/DM	Date APRIL 2006
Project Engineer M.G.LYONS	Date MAY 2006

URBAN PARK & OPEN SPACE SIGNAGE

TOWN PARK IDENTIFICATION
AND INFORMATION SIGN

Scale 1:25, 1:5 @ A3	Date MAY 2006
AutoCAD File DS25-01.DWG	Drawing No. DS25-01
	Sheet No. 1

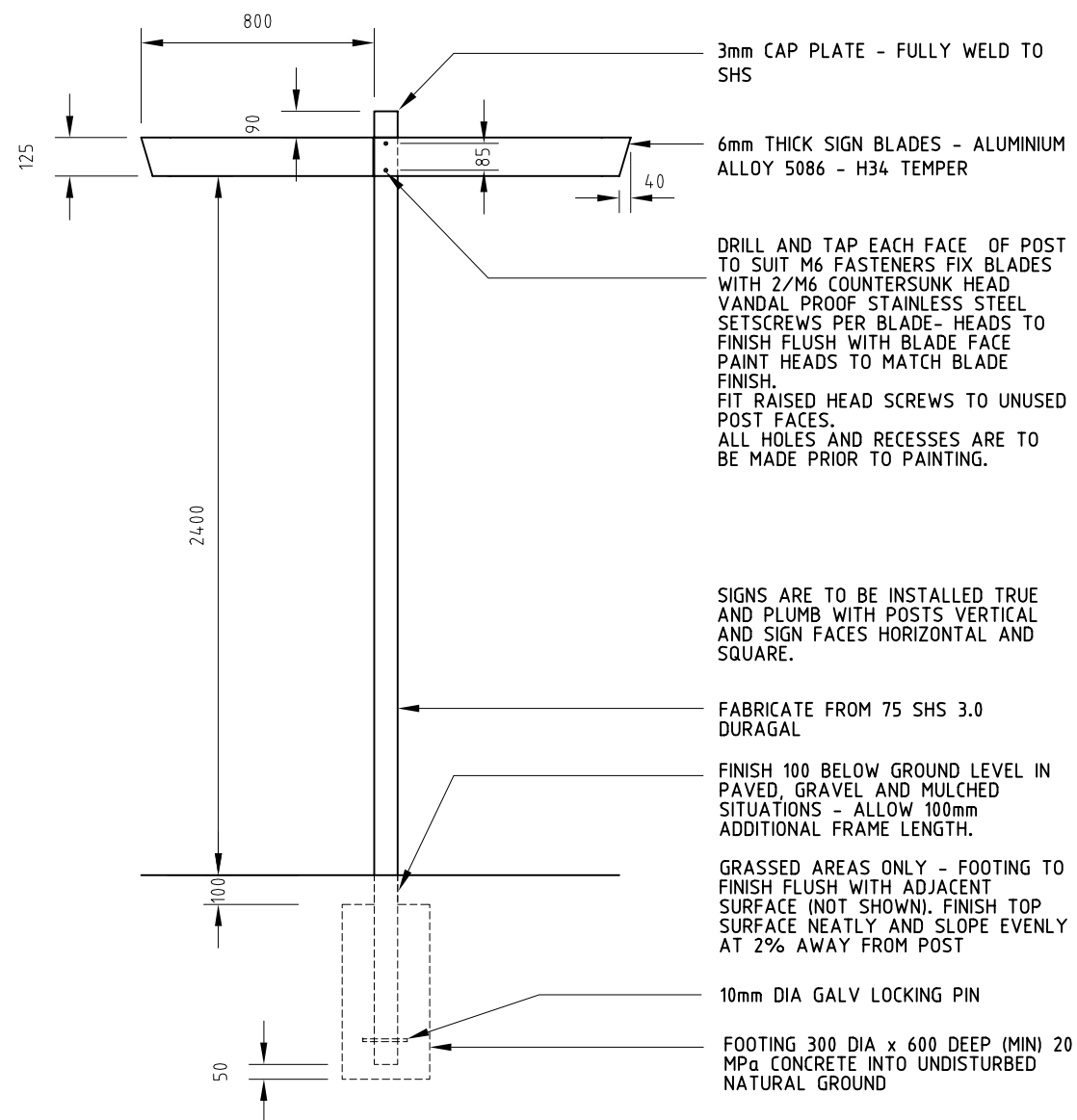

ELEVATION

1:25

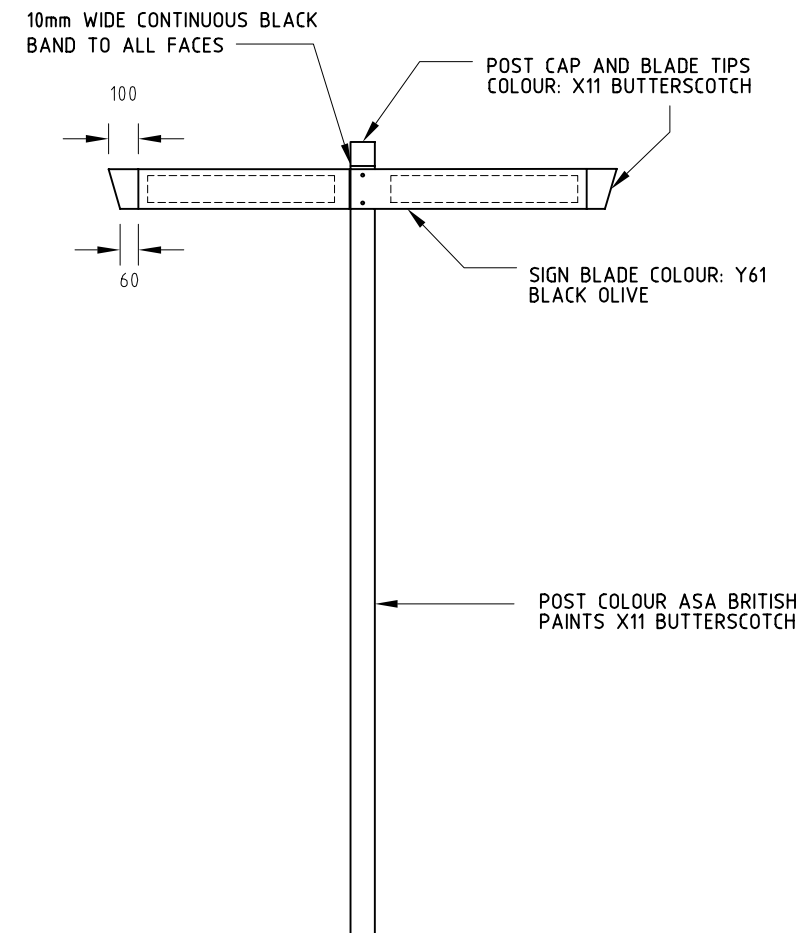
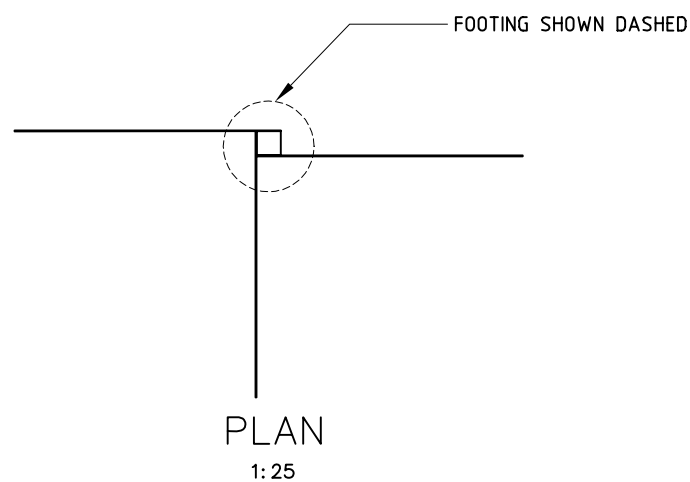



FINISHES AND TYPICAL GRAPHIC LAYOUT

1:25

NOTES

- ALL WORK AND MATERIALS ARE TO COMPLY WITH THE LATEST RELEVANT AUSTRALIAN STANDARDS AND CODES.
- GRAPHICS, TEXT & LOGOS TO PROJECT REQUIREMENTS AND ACT GOVERNMENT BRANDING POLICY AT TIME OF INSTALLATION. REFER DESIGN STANDARD 25 FOR GRAPHIC GUIDELINES.
- GRIND WELDS SMOOTH AND REMOVE WELD SPATTER. MAKE SMOOTH ALL SHARP OR HAZARDOUS EDGES. COLD GALVANISE PAINT ALL AREAS DISTURBED PRIOR TO PAINT FINISH APPLICATION.
- FOR GALVANISED SURFACES SURFACE PREPARATION MAY INVOLVE DEGREASING, SOLVENT CLEANING AND ETCHING OR LIGHT BRUSH BLASTING. FINISHED SURFACES ARE TO BE SMOOTH AND FLAT WITH PAINT EVENLY APPLIED.
- PAINT FINISH SHALL BE EQUAL TO DEBEER COLOUR SYSTEMS BERTHANE FLEET SERIES 700 - HIGH GLOSS, NON-YELLOWING, 2-PACK POLYURETHANE FINISH (AIR-DRYING OR FORCE-DRYING). INCLUDE SURFACE PREPARATION, EDGE PRIMER, UNDERCOAT PRIMER, 2 SATIN FINISH FINISHING COATS OF PAINT AND 2 HEAVY FINISHING COATS OF CLEAR TWO PACK POLYURETHANE.
- SIGN MESSAGES, GRAPHICS AND PICTOGRAMS MASKED AND SPRAYED ON PAINTED SIGN FACES. ALL GRAPHICS TO BE PERMANENTLY APPLIED AND ACCURATELY REPRODUCED FROM ELECTRONIC FILES.
- TREAT ALL EXPOSED SURFACES WITH APPROVED SACRIFICIAL, INVISIBLE ANTI GRAFFITI TREATMENT SUCH AS PSS 20 OR EQUAL.

ACT GOVERNMENT	
 	
DESIGN STANDARD	
URBAN INFRASTRUCTURE	
Authorised Signature	
Drawn JP/DM	Date APRIL 2006
Project Engineer M.G.LYONS	Date MAY 2006
URBAN PARK & OPEN SPACE SIGNAGE	
TOWN PARK DIRECTION SIGN	
Scale 1:25, 1:5 @ A3	Date MAY 2006
AutoCAD File	
DS25-02.DWG	
Drawing No. DS25-02	Sheet No. 2

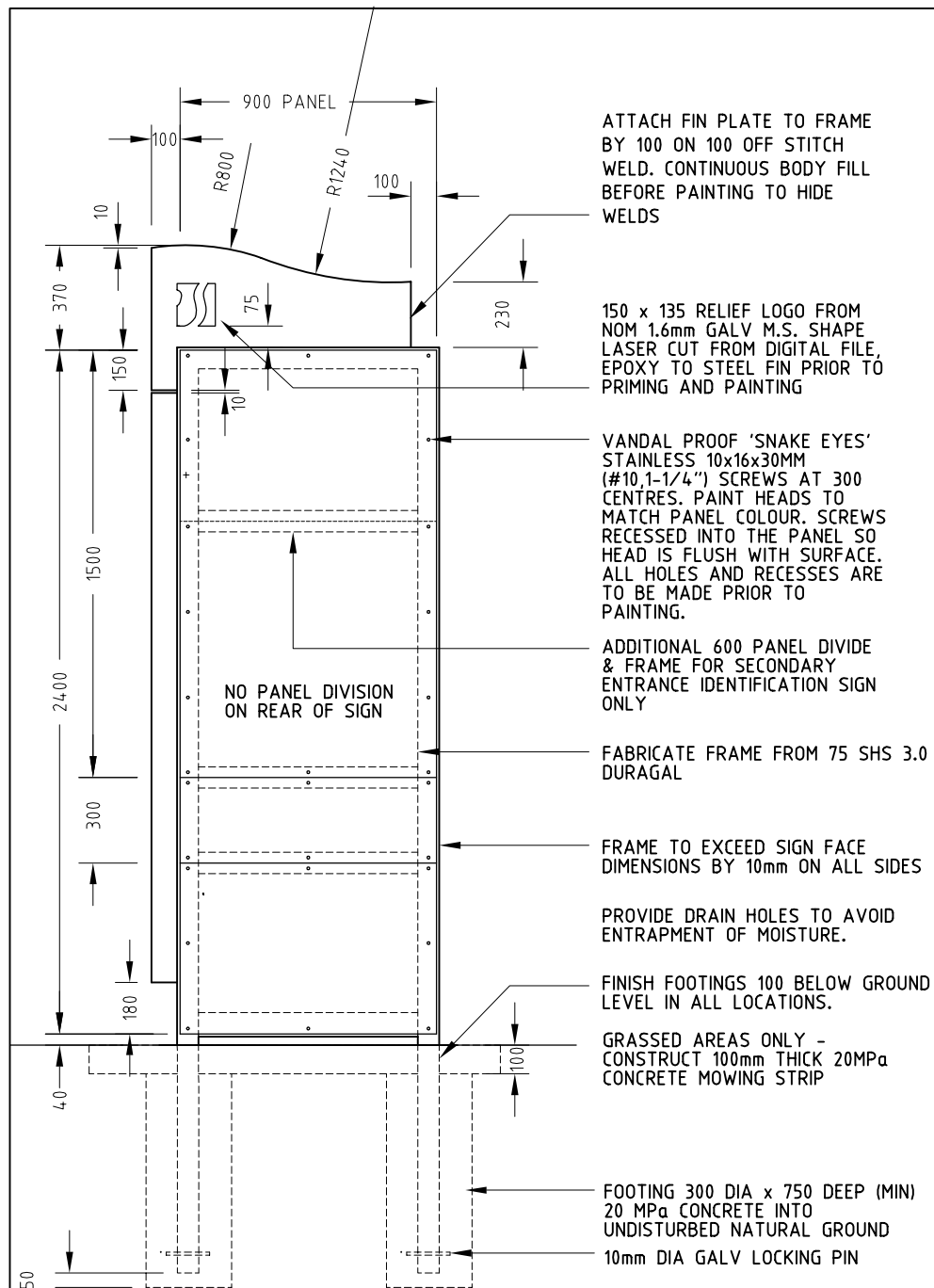

ELEVATION

1:25

ATTACH FIN PLATE TO FRAME BY 100 ON 100 OFF STITCH WELD. CONTINUOUS BODY FILL BEFORE PAINTING TO HIDE WELDS

150 x 135 RELIEF LOGO FROM NOM 1.6mm GALV M.S. SHAPE LASER CUT FROM DIGITAL FILE. EPOXY TO STEEL FIN PRIOR TO PRIMING AND PAINTING

VANDAL PROOF 'SNAKE EYES' STAINLESS 10x16x30MM (#10, 1-1/4") SCREWS AT 300 CENTRES. PAINT HEADS TO MATCH PANEL COLOUR. SCREWS RECESSED INTO THE PANEL SO HEAD IS FLUSH WITH SURFACE. ALL HOLES AND RECESSES ARE TO BE MADE PRIOR TO PAINTING.

ADDITIONAL 600 PANEL DIVIDE & FRAME FOR SECONDARY ENTRANCE IDENTIFICATION SIGN ONLY

NO PANEL DIVISION ON REAR OF SIGN

FABRICATE FRAME FROM 75 SHS 3.0 DURAGAL

FRAME TO EXCEED SIGN FACE DIMENSIONS BY 10mm ON ALL SIDES

PROVIDE DRAIN HOLES TO AVOID ENTRAPMENT OF MOISTURE.

FINISH FOOTINGS 100 BELOW GROUND LEVEL IN ALL LOCATIONS.

GRASSED AREAS ONLY - CONSTRUCT 100mm THICK 20MPa CONCRETE MOWING STRIP

FOOTING 300 DIA x 750 DEEP (MIN) 20 MPa CONCRETE INTO UNDISTURBED NATURAL GROUND

10mm DIA GALV LOCKING PIN

SIGNS ARE TO BE INSTALLED TRUE AND PLUMB WITH POSTS VERTICAL AND SIGN FACES HORIZONTAL AND SQUARE.

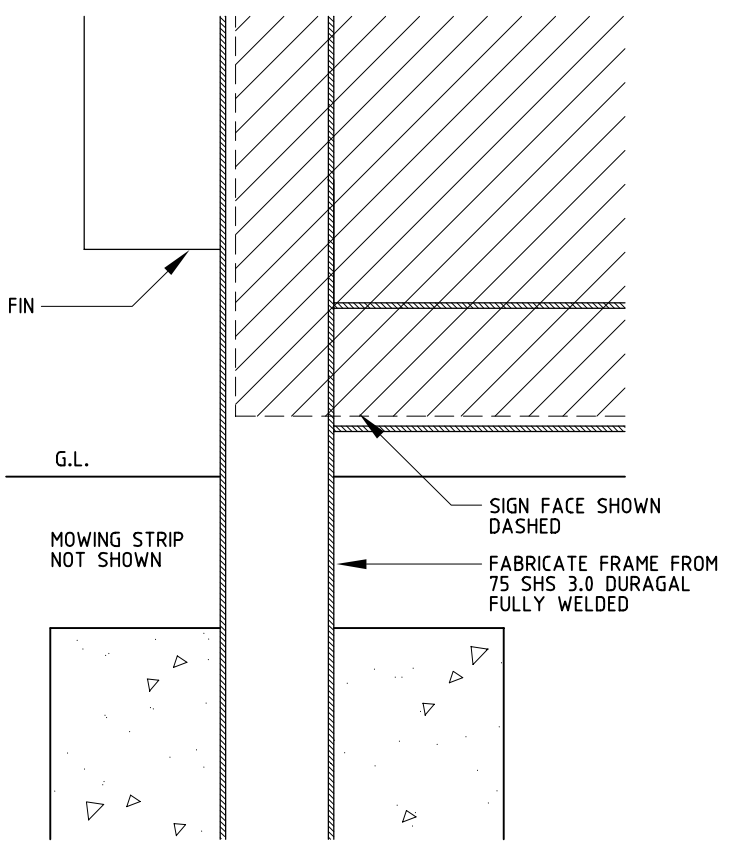

DETAIL
SECTION 1:5

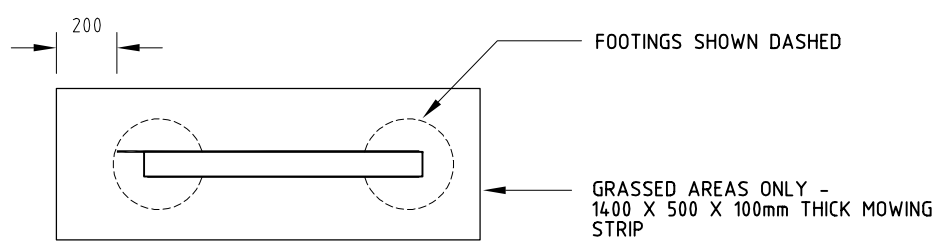

PLAN

1:25

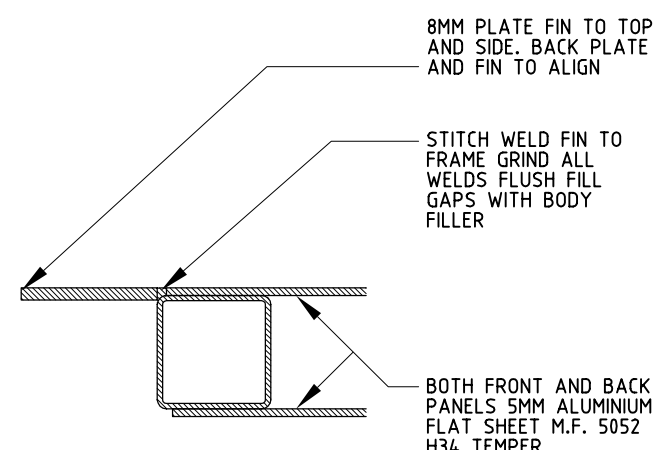

DETAIL
PLAN 1:5

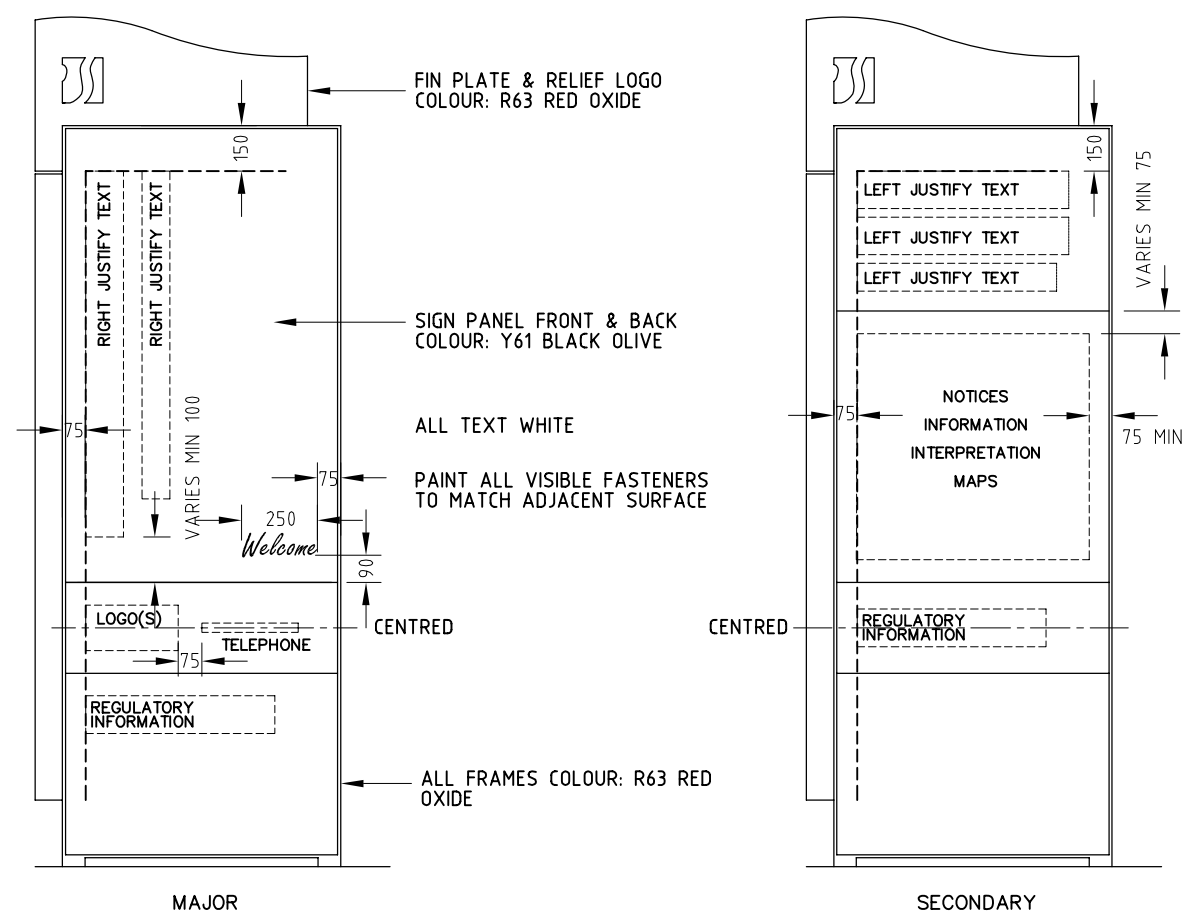

FINISHES & TYPICAL GRAPHIC LAYOUT

1:25

NOTES

1. ALL WORK AND MATERIALS ARE TO COMPLY WITH THE LATEST RELEVANT AUSTRALIAN STANDARDS AND CODES.
2. GRAPHICS, TEXT & LOGOS TO PROJECT REQUIREMENTS AND ACT GOVERNMENT BRANDING POLICY AT TIME OF INSTALLATION. REFER DESIGN STANDARD 25 FOR GRAPHIC GUIDELINES.
3. GRIND WELDS SMOOTH AND REMOVE WELD SPATTER. MAKE SMOOTH ALL SHARP OR HAZARDOUS EDGES. COLD GALVANISE PAINT ALL AREAS DISTURBED PRIOR TO PAINT FINISH APPLICATION.
4. FOR GALVANISED SURFACES SURFACE PREPARATION MAY INVOLVE DEGREASING, SOLVENT CLEANING AND ETCHING OR LIGHT BRUSH BLASTING. FINISHED SURFACES ARE TO BE SMOOTH AND FLAT WITH PAINT EVENLY APPLIED.
5. PAINT FINISH SHALL BE EQUAL TO DE BEER COLOUR SYSTEMS BERTHANE FLEET SERIES 700 - HIGH GLOSS, NON-YELLOWING, 2-PACK POLYURETHANE FINISH (AIR-DRYING OR FORCE-DRYING). INCLUDE SURFACE PREPARATION, EDGE PRIMER, UNDERCOAT PRIMER, 2 SATIN FINISH FINISHING COATS OF PAINT AND 2 HEAVY FINISHING COATS OF CLEAR TWO PACK POLYURETHANE.
6. SIGN MESSAGES, GRAPHICS AND PICTOGRAMS MASKED AND SPRAYED ON PAINTED SIGN FACES. ALL GRAPHICS TO BE PERMANENTLY APPLIED AND ACCURATELY REPRODUCED FROM ELECTRONIC FILES.
7. TREAT ALL EXPOSED SURFACES WITH APPROVED SACRIFICIAL, INVISIBLE ANTI GRAFFITI TREATMENT SUCH AS PSS 20 OR EQUAL.

ACT GOVERNMENT

URBAN SERVICES

DESIGN STANDARD
URBAN INFRASTRUCTURE

Authorised Signature _____ Date _____

Drawn JP/DM Date APRIL 2006

Project Engineer M.G.LYONS Date MAY 2006

URBAN PARK & OPEN SPACE SIGNAGE

DISTRICT PARK
MAJOR & SECONDARY
IDENTIFICATION SIGN

Scale 1:25, 1:5 @ A3	Date MAY 2006
AutoCAD File DS25-03.DWG	
Drawing No. DS25-03	Sheet No. 3

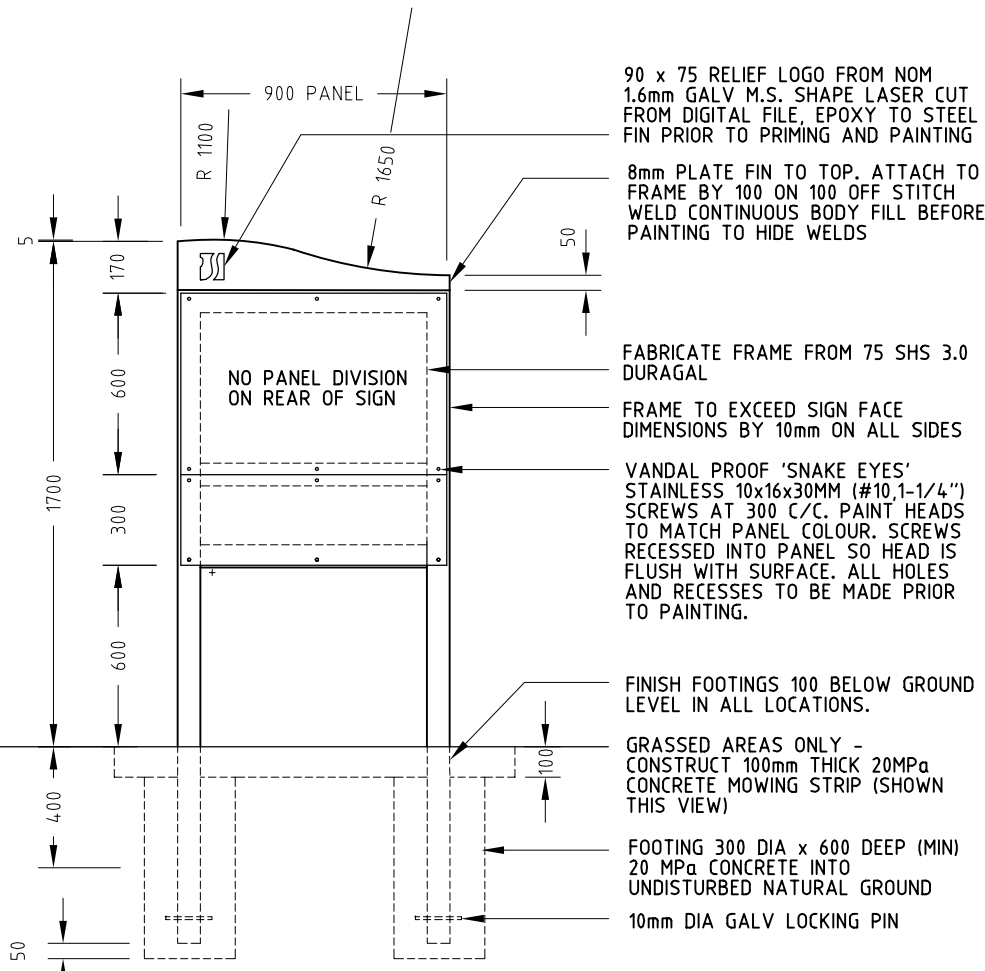

ELEVATION
1:25

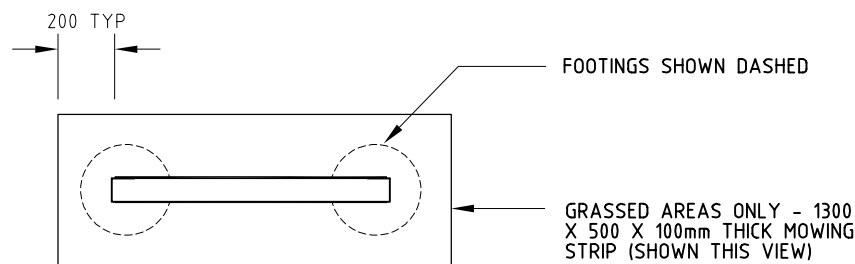

PLAN
1:25

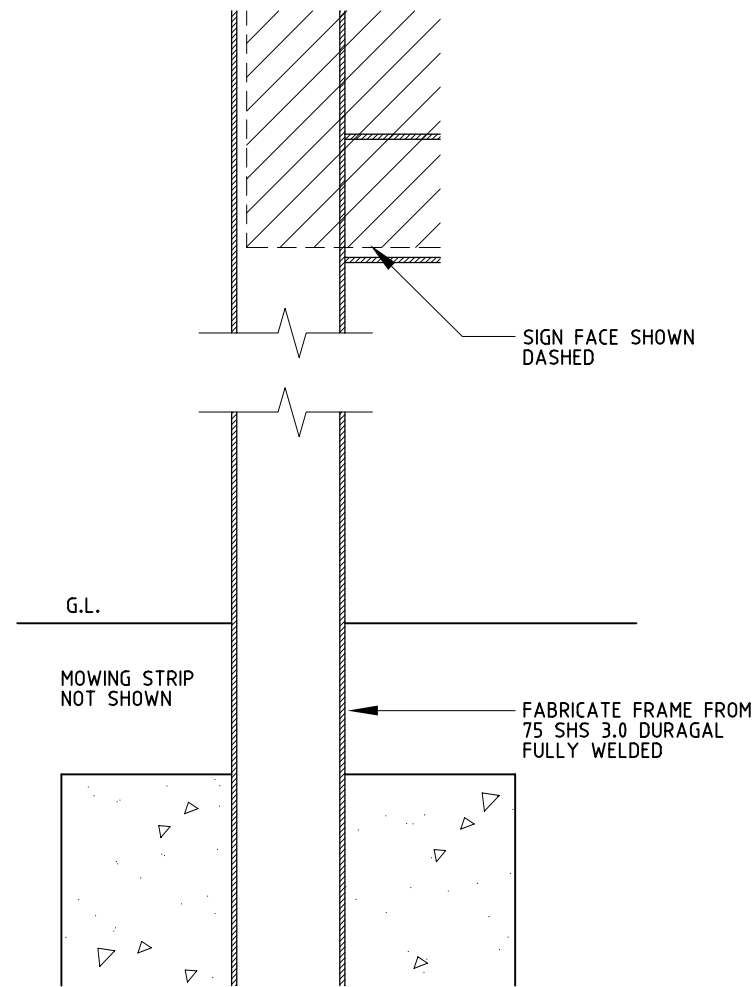

DETAIL
SECTION 1:5

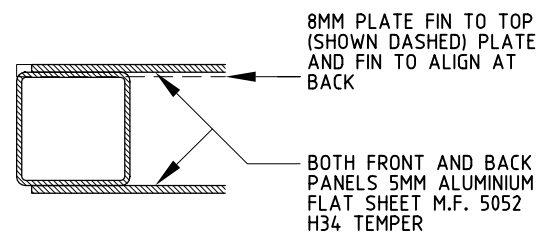

DETAIL
PLAN 1:5

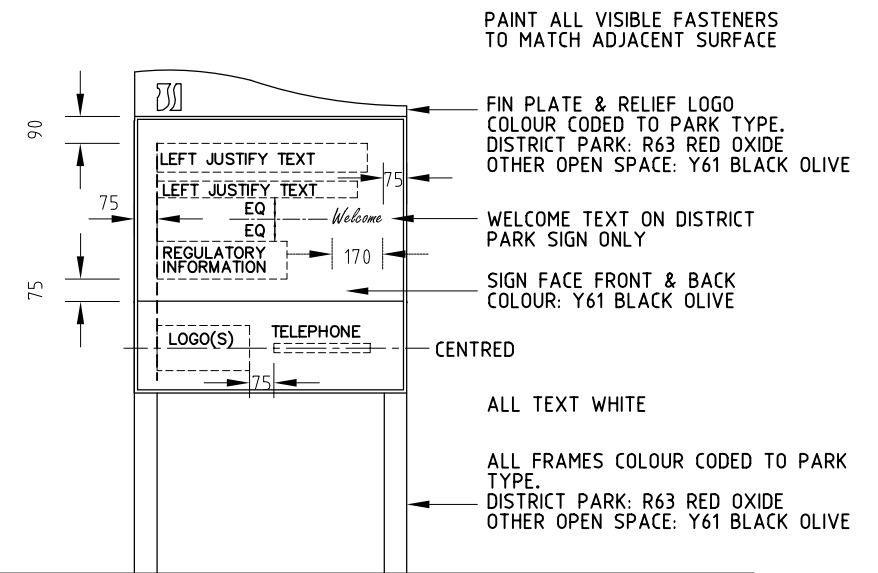

FINISHES & TYPICAL GRAPHIC LAYOUT
1:25

NOTES

- ALL WORK AND MATERIALS ARE TO COMPLY WITH THE LATEST RELEVANT AUSTRALIAN STANDARDS AND CODES.
- GRAPHICS, TEXT & LOGOS TO PROJECT REQUIREMENTS AND ACT GOVERNMENT BRANDING POLICY AT TIME OF INSTALLATION. REFER DESIGN STANDARD 25 FOR GRAPHIC GUIDELINES.
- GRIND WELDS SMOOTH AND REMOVE WELD SPATTER. MAKE SMOOTH ALL SHARP OR HAZARDOUS EDGES. COLD GALVANISE PAINT ALL AREAS DISTURBED PRIOR TO PAINT FINISH APPLICATION.
- FOR GALVANISED SURFACES SURFACE PREPARATION MAY INVOLVE DEGREASING, SOLVENT CLEANING AND ETCHING OR LIGHT BRUSH BLASTING. FINISHED SURFACES ARE TO BE SMOOTH AND FLAT WITH PAINT EVENLY APPLIED.
- PAINT FINISH SHALL BE EQUAL TO DE BEER COLOUR SYSTEMS BERTHANE FLEET SERIES 700 - HIGH GLOSS, NON-YELLOWING, 2-PACK POLYURETHANE FINISH (AIR-DRYING OR FORCE-DRYING). INCLUDE SURFACE PREPARATION, EDGE PRIMER, UNDERCOAT PRIMER, 2 SATIN FINISH FINISHING COATS OF PAINT AND 2 HEAVY FINISHING COATS OF CLEAR TWO PACK POLYURETHANE.
- SIGN MESSAGES, GRAPHICS AND PICTOGRAMS MASKED AND SPRAYED ON PAINTED SIGN FACES. ALL GRAPHICS TO BE PERMANENTLY APPLIED AND ACCURATELY REPRODUCED FROM ELECTRONIC FILES.
- TREAT ALL EXPOSED SURFACES WITH APPROVED SACRIFICIAL, INVISIBLE ANTI GRAFFITI TREATMENT SUCH AS PSS 20 OR EQUAL.

ACT GOVERNMENT	
URBAN SERVICES	
DESIGN STANDARD	
URBAN INFRASTRUCTURE	
Authorised Signature	
Drawn JP/DM	Date APRIL 2006
Project Engineer M.G.LYONS	Date MAY 2006
URBAN PARK & OPEN SPACE SIGNAGE	
DISTRICT PARK & URBAN OPEN SPACE MINOR IDENTIFICATION SIGN	
Scale 1:25, 1:5 @ A3	Date MAY 2006
AutoCAD File DS25-04.DWG	
Drawing No. DS25-04	Sheet No. 4

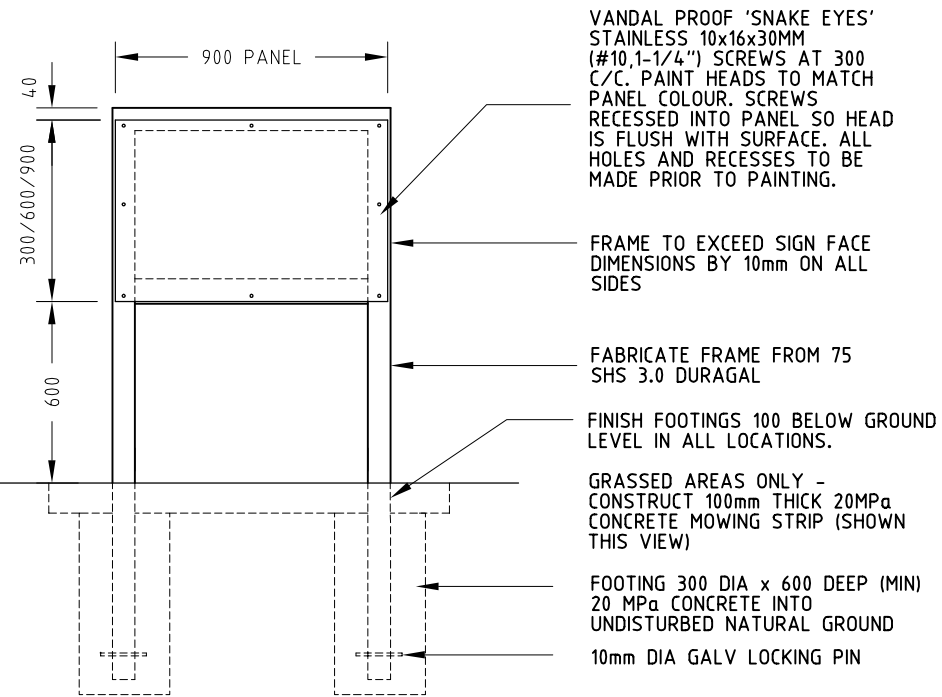

ELEVATION
(300 / 600 / 900 PANEL) 1:25

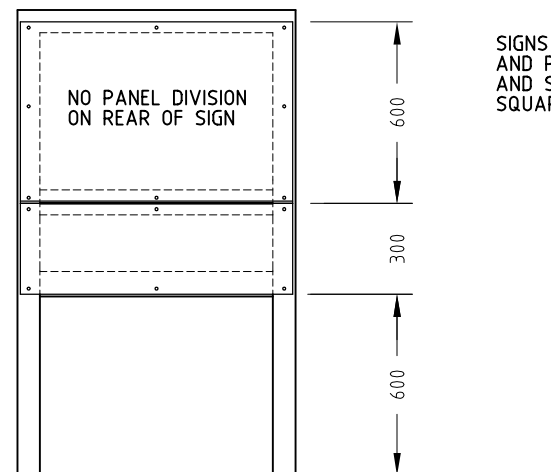

ELEVATION
(DUAL PANEL ALTERNATIVE) 1:25

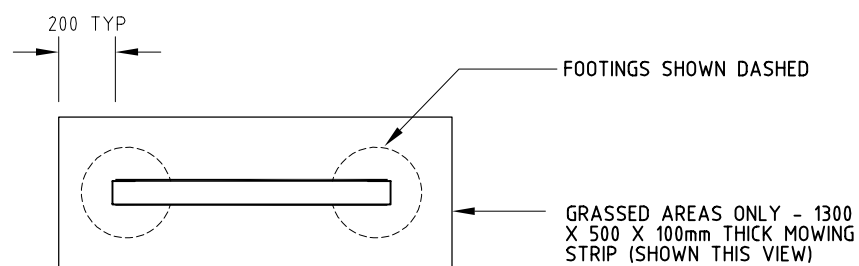

PLAN
1:25

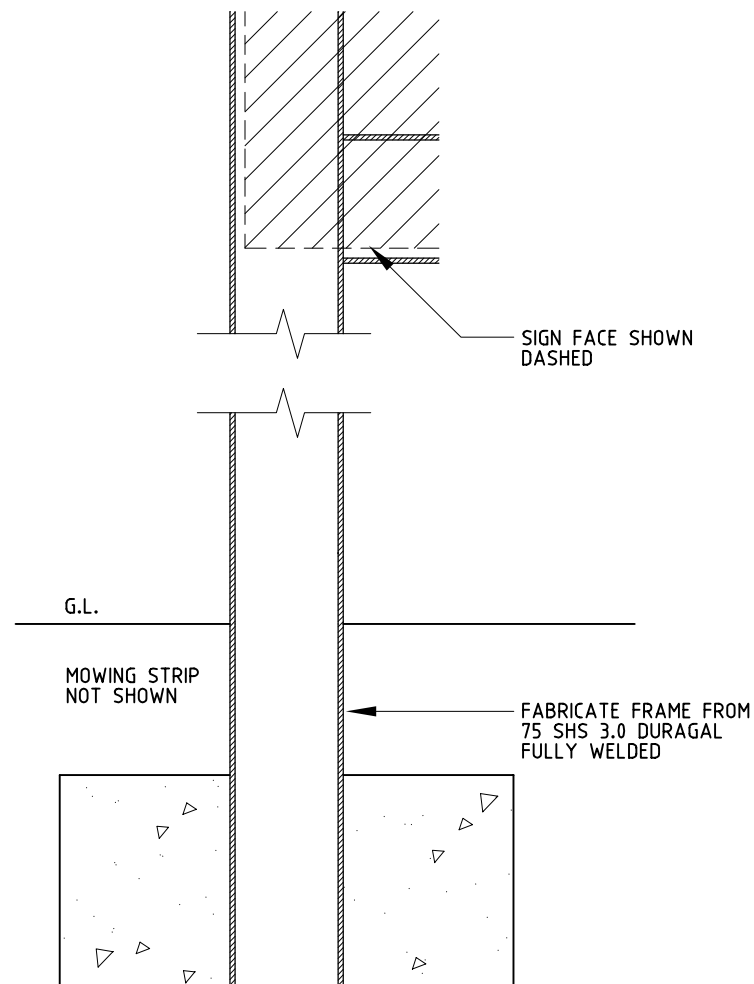

DETAIL
SECTION 1:5

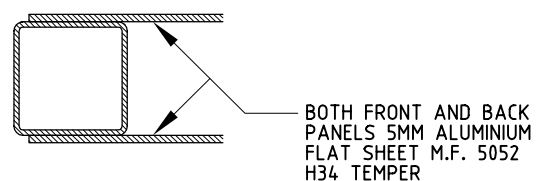

DETAIL
PLAN 1:5

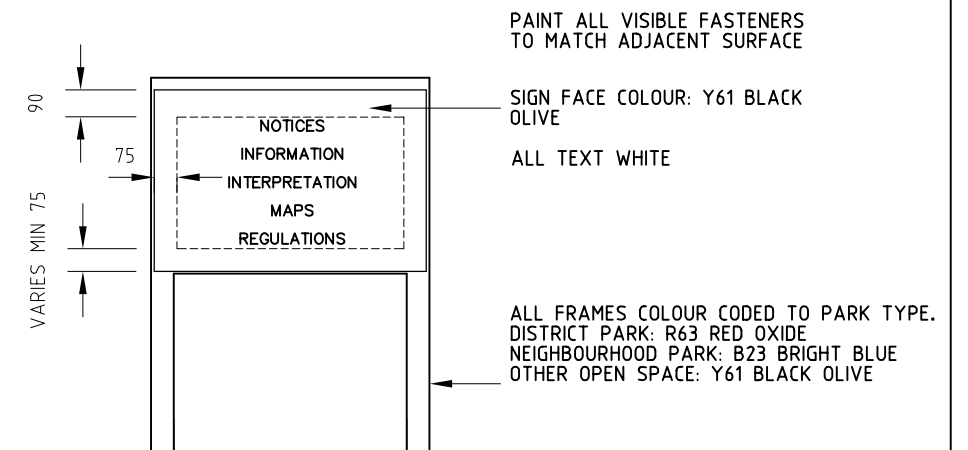

FINISHES & TYPICAL GRAPHIC LAYOUT
1:25

NOTES

- ALL WORK AND MATERIALS ARE TO COMPLY WITH THE LATEST RELEVANT AUSTRALIAN STANDARDS AND CODES.
- GRAPHICS, TEXT & LOGOS TO PROJECT REQUIREMENTS AND ACT GOVERNMENT BRANDING POLICY AT TIME OF INSTALLATION. REFER DESIGN STANDARD 25 FOR GRAPHIC GUIDELINES.
- GRIND WELDS SMOOTH AND REMOVE WELD SPATTER. MAKE SMOOTH ALL SHARP OR HAZARDOUS EDGES. COLD GALVANISE PAINT ALL AREAS DISTURBED PRIOR TO PAINT FINISH APPLICATION.
- FOR GALVANISED SURFACES SURFACE PREPARATION MAY INVOLVE DEGREASING, SOLVENT CLEANING AND ETCHING OR LIGHT BRUSH BLASTING. FINISHED SURFACES ARE TO BE SMOOTH AND FLAT WITH PAINT EVENLY APPLIED.
- PAINT FINISH SHALL BE EQUAL TO DE BEER COLOUR SYSTEMS BEROETHANE FLEET SERIES 700 - HIGH GLOSS, NON-YELLOWING, 2-PACK POLYURETHANE FINISH (AIR-DRYING OR FORCE-DRYING). INCLUDE SURFACE PREPARATION, EDGE PRIMER, UNDERCOAT PRIMER, 2 SATIN FINISH FINISHING COATS OF PAINT AND 2 HEAVY FINISHING COATS OF CLEAR TWO PACK POLYURETHANE.
- SIGN MESSAGES, GRAPHICS AND PICTOGRAMS MASKED AND SPRAYED ON PAINTED SIGN FACES. ALL GRAPHICS TO BE PERMANENTLY APPLIED AND ACCURATELY REPRODUCED FROM ELECTRONIC FILES.
- TREAT ALL EXPOSED SURFACES WITH APPROVED SACRIFICIAL, INVISIBLE ANTI GRAFFITI TREATMENT SUCH AS PSS 20 OR EQUAL.

ACT GOVERNMENT	
URBAN SERVICES	
DESIGN STANDARD	
URBAN INFRASTRUCTURE	
Authorised Signature	
Drawn JP/DM	Date APRIL 2006
Project Engineer M.G.LYONS	Date MAY 2006
URBAN PARK & OPEN SPACE SIGNAGE	
DISTRICT PARK & URBAN OPEN SPACE INFORMATION & DIRECTION SIGN	
Scale 1:25, 1:5 @ A3	Date MAY 2006
AutoCAD File DS25-05.DWG	
Drawing No. DS25-05	Sheet No. 5

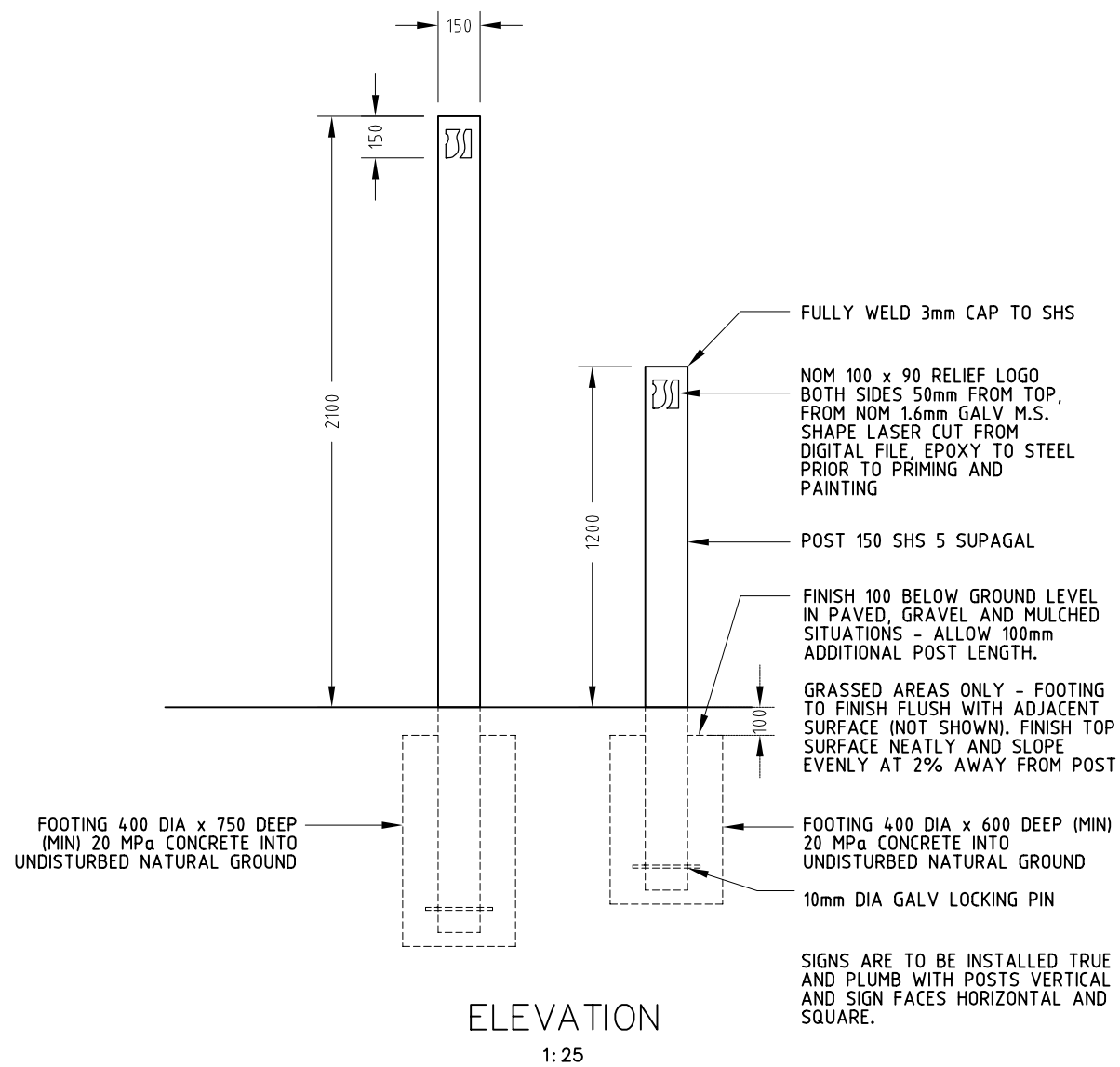

ELEVATION
1:25

ALTERNATIVE TIMBER CONSTRUCTION (ONLY WHERE APPROVED BY PARKS & PLACES)

SIGN FROM 150X150 NON-ARSENIC PRESERVATIVE TREATED DRESSED ALL ROUND SOFTWOOD TIMBER FINISHED WITH ACRYLIC PAINT. ENSURE ALL KNOTS AND GROOVES HAVE BEEN ADEQUATELY TREATED TO ENSURE A SMOOTH SURFACE. CUT 2% SLOPE TO DRAIN TOP. LETTERING AND ARROWS ARE ROUTED AND PAINT FILLED USING WHITE SIGNWRITERS ENAMEL SUCH AS "FLORITE". LOGOS AND PICTOGRAMS ARE TO BE PRINTED ON ALUMINIUM GLUED INTO SQUARE ROUTED RECESSES. DIRECT BURY INTO 400 DIA x SPECIFIED DEPTH 20MPa CONCRETE FOOTING.

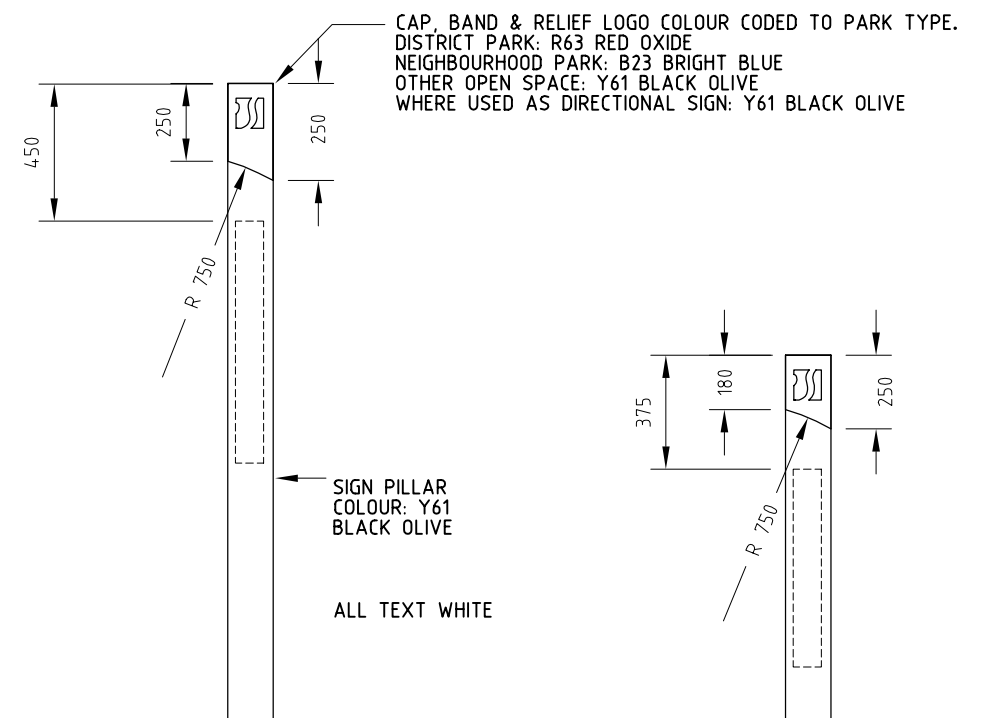

FINISHES & TYPICAL GRAPHIC LAYOUT
1:25

NOTES

1. ALL WORK AND MATERIALS ARE TO COMPLY WITH THE LATEST RELEVANT AUSTRALIAN STANDARDS AND CODES.
2. GRAPHICS, TEXT & LOGOS TO PROJECT REQUIREMENTS AND ACT GOVERNMENT BRANDING POLICY AT TIME OF INSTALLATION. REFER DESIGN STANDARD 25 FOR GRAPHIC GUIDELINES.
3. GRIND WELDS SMOOTH AND REMOVE WELD SPATTER. MAKE SMOOTH ALL SHARP OR HAZARDOUS EDGES. COLD GALVANISE PAINT ALL AREAS DISTURBED PRIOR TO PAINT FINISH APPLICATION.
4. FOR GALVANISED SURFACES SURFACE PREPARATION MAY INVOLVE DEGREASING, SOLVENT CLEANING AND ETCHING OR LIGHT BRUSH BLASTING. FINISHED SURFACES ARE TO BE SMOOTH AND FLAT WITH PAINT EVENLY APPLIED.
5. PAINT FINISH SHALL BE EQUAL TO DE BEER COLOUR SYSTEMS BERTHANE FLEET SERIES 700 - HIGH GLOSS, NON-YELLOWING, 2-PACK POLYURETHANE FINISH (AIR-DRYING OR FORCE-DRYING). INCLUDE SURFACE PREPARATION, EDGE PRIMER, UNDERCOAT PRIMER, 2 SATIN FINISH FINISHING COATS OF PAINT AND 2 HEAVY FINISHING COATS OF CLEAR TWO PACK POLYURETHANE.
6. SIGN MESSAGES, GRAPHICS AND PICTOGRAMS MASKED AND SPRAYED ON PAINTED SIGN FACES. ALL GRAPHICS TO BE PERMANENTLY APPLIED AND ACCURATELY REPRODUCED FROM ELECTRONIC FILES.
7. TREAT ALL EXPOSED SURFACES WITH APPROVED SACRIFICIAL, INVISIBLE ANTI GRAFFITI TREATMENT SUCH AS PSS 20 OR EQUAL.

ACT GOVERNMENT	
URBAN SERVICES	
DESIGN STANDARD	
URBAN INFRASTRUCTURE	
Authorised Signature	
Drawn JP/DM	Date APRIL 2006
Project Engineer M.G.LYONS	Date MAY 2006
URBAN PARK & OPEN SPACE SIGNAGE	
NEIGHBOURHOOD PARK IDENTIFICATION & INFORMATION SIGN	
Scale 1:25, 1:5 @ A3	Date MAY 2006
AutoCAD File DS25-06.DWG	
Drawing No. DS25-06	Sheet No. 6